

THIS DRAWING / DESIGN IS STRICTLY CONFIDENTIAL & THE  
 COPYRIGHT THEREIN THE EXCLUSIVE PROPERTY OF  
**MOBILE CLIMATE CONTROL INC.**  
 AND MAY NOT BE USED OR COPIED OR EXHIBITED WITHOUT  
 THEIR WRITTEN PERMISSION.

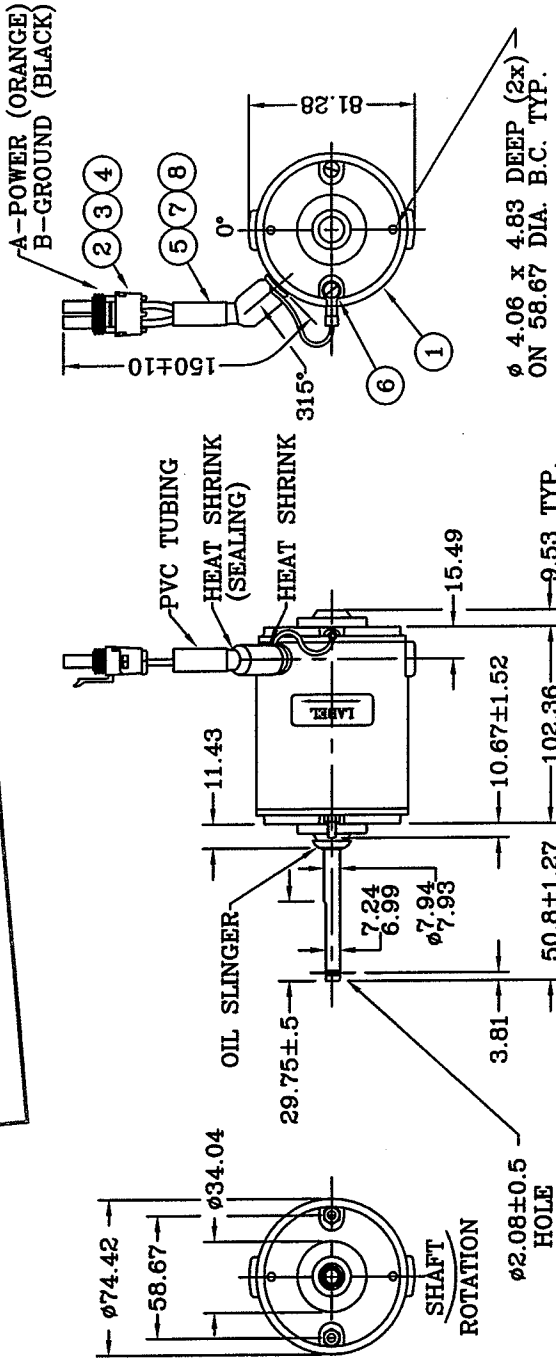

$\phi 4.06 \times 4.83$  DEEP (2x)  
 ON  $58.67$  DIA. B.C. TYP.

NOTES:

- EMI SUPPRESSED TO MIL-STD-461C PART 4 CE03 AND PART 8 UM03
- FLUX RING PAINTED BLACK.
- MOTOR HAS SLEEVE BEARINGS AND LONG LIFE BRUSHES.
- LEAD WIRE OF 14GA GPT (105°).
- SEAL AROUND CASE BOLT, STRAIN RELIEF, END CASE AND BRUSH CAPS.

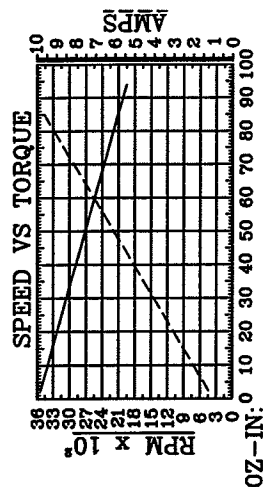

DESIGNATED LOAD POINT: 60 OZ IN AT 2550 RPM.  
 MOTOR ROTATION: CCWSE ORANGE LEAD POSITIVE

SYM	PCS	PART NO.	DESCRIPTION
8	1	31-1246	CAP SPLICER 22-14GA
7	2	31-1063	BUTT SPLICER 10-12GA (INSUL.)
6	2	31-1044	INS. RING TERMINAL 10-12GA #8
5	2	25-0422	CAPACTOR 0.1 $\mu$ F 250 VDC POLY
4	2	31-1026	TERMINAL FEM. 14GA (WP) 12124580-L
3	1	31-1025	CONNECTOR 2 WAY FEM. (WP) 12015792
2	1	31-1024	SEAL (WP CONNECTOR) 12010293
1	1	25-0202	MOTOR 24V (EMI)

CHECKED BY: <i>WJ</i>	DATE: <i>6/18/07</i>	DESCRIPTION	SCALE: NTS	BT: HN
		25-0285	DATE: JAN 25, 1993	
		MOTOR 24V (EMI)	DWG: P3-1429	REF: 2

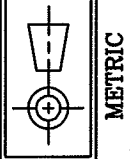

THIS PRINT IS PROVIDED ON A RESTRICTED BASIS AND IS NOT TO BE USED IN ANY WAY DETRIMENTAL TO THE INTEREST OF MOBILE CLIMATE CONTROL INC.

REV	DESCRIPTION	DATE	BY
2	REVISED AS PER ECN #3304	JUNE 11, 02 MS	
1	EMI FILTER ADDED	JUNE 20, 94 CM	
BTM	REVISION		