

2.5" HOSE  
ADAPTER (2x)

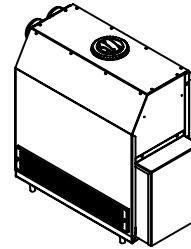
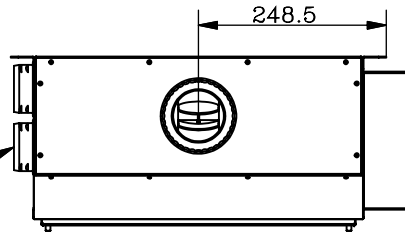

**SPECIFICATION:**

COOLING - 8350 W (28,500 BTU/H)  
 HEATING - 12370 W (42,200 BTU/H)  
 AIRFLOW - 450 CFM  
 CURRENT - 11 AMPS AT HIGH SPEED  
 WEIGHT - 18 KG (39 LBS)  
 (ALL THE DATA FOR HEATER/AC UNIT ONLY.)

CASING MADE OF 18GA CRS AND FINISHED IN  
 BLACK SEMI GLOSS EPOXY POWDER COAT.

LOUVER

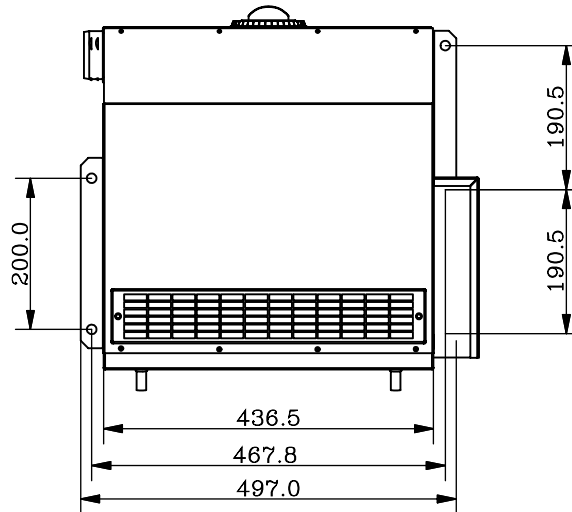
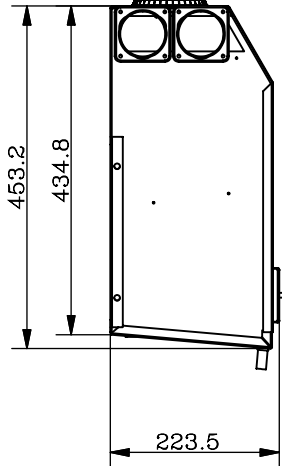

**CONNECTIONS:**

EVAPORATOR (BLOCK VALVE, P/N 26-0190)  
 5/8"-18FE, O-RING #6 (INLET)  
 7/8"-18FE, O-RING #10 (OUTLET)

**HEATER**

(2X) 5/8" OD. WITH STANDARD HOSE BEAD

MCC 37				

SYM	DESCRIPTION	DATE	BY

TOLERANCE UNLESS OTHERWISE SPECIFIED							
ANG.	0.5	3	6	30	120	315	1000
	3	6	30	120	315	1000	2000
±1	±0.15	±0.2	±0.5	±0.8	±1.2	±2	±3
							±4

THIS PRINT IS PROVIDED ON A RESTRICTED BASIS  
 AND IS NOT TO BE USED IN ANY WAY DETRIMENTAL  
 TO THE INTEREST OF MOBILE CLIMATE CONTROL

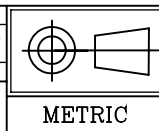

CHECKED: \_\_\_\_\_ DATE: \_\_\_\_\_

**MCC Mobile Climate Control Inc.**  
 Toronto - Ontario - Canada

SYM	PCS	PART NO.	DESCRIPTION
		13-3032	HEATER A/C 24V

SCALE: NTS BY: SG  
 DATE: 4/22/2005  
 DWG: 13-3032.idw REV: C